

ROTARY TUMBLER

INSTRUCTIONS AND PARTS LIST

Model
3-1.5B



Model
45C



Model
33B



LORTONE

12130 Cyrus Way
Mukilteo, WA 98275
(425) 493-1600

SETTING UP YOUR MACHINE

For 45C Unit Only (33B & 3-1.5B already assembled)

Install The Barrel Guide: Using the machine screw provided, install the barrel guide on top of the frame edge as shown in the picture.

- I. Place the barrel on the tumbler and align. Align the slot in the guide with the groove in the knurled nut on the barrel. (figure 1.)
- II. Adjust the position of the guide so the slot is centered on the groove. Tighten the screw securely with the nut provided. (figure 2.)

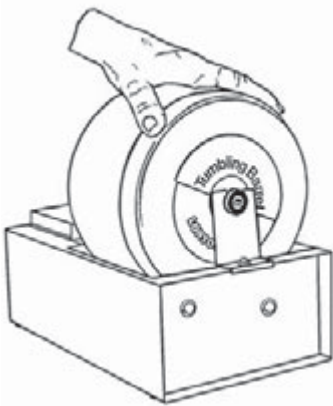

fig. 1

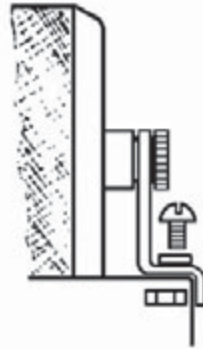

fig. 2

Install Barrel guide over the tumbler frame edge. Place barrel on the tumbler and align before tightening the screw. Once aligned, tighten screw and nut securely.

GETTING STARTED

- I. Open the Barrel:** Remove nut and washer, press down on bolt with thumb while lifting up on outside of outer lid with fingers. If outer lid is difficult to remove, insert washer between edge of outer lid and barrel, twist to loosen. After outer lid has been removed, lift inner lid out by center bolt.



- II. Add Rocks:** Fill Barrel about 1/2 to 2/3 full of rock. Rocks should be of assorted sizes for best results.



- III. Add Abrasive:** Add 60/90 Silicon Carbide Abrasive. Use 4 level Tbsp for a 1.5 - 3 Lb. barrel. Use 6-8 level Tbsp for a 4 lb. barrel.

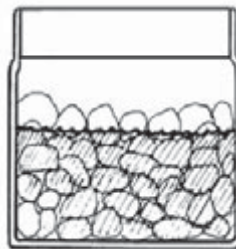

Add rocks until 2/3 full. Add water to top layer of rocks.

Add water to top layer of rocks and abrasive.

Do not overfill.

- IV. Close the Barrel:** Wipe the mating surfaces of the barrel and inner lid clean with a damp cloth. Press inner lid into barrel until it rests on shoulder. Press outer lid firmly down onto the barrel. Install washer and tighten nut.

Knurled nut only needs to be snug Do Not Use tools to tighten. Over tightening of the nut can cause the inner lid to distort and leak.

Plug tumbler
in and place
barrel on
tumbler.

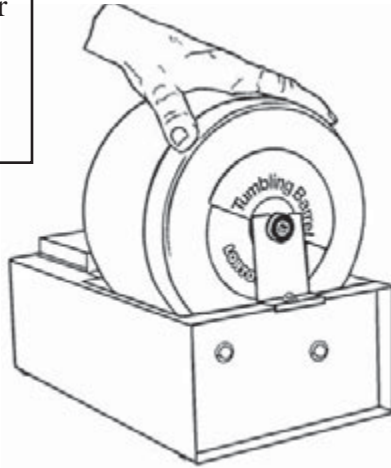

V. Tumble: Plug the tumbler into a suitable outlet. Place the barrel on the tumbler making sure the groove in the barrel nut sits on the tumbler guide (45C). Tumble for 2-3 days. Open and check the rocks. The rough edges should be wearing down. After 5-7 days, open the barrel and rinse the rocks in a bucket of water. **DO NOT** put the rinse water down a household drain as it will clog the drain!

IMPORTANT: Clean the rocks and barrel parts thoroughly using mild soap and water!

VI. Repeat steps II through V: Use successively finer abrasives according to your tumbling instruction booklet and the chart below:

	Step 1	Step 2	Step 3	Step 4
Compound	60/90 Silicon Carbide	120/220 Silicon Carbide	Pre-Polish Aluminum Oxide	Polish Aluminum Oxide
1.5 lb Barrel	2-4 Tbsp	2-4 Tbsp	3-5 Tbsp	3-5 Tbsp
3 lb Barrel	4 Tbsp	4 Tbsp	4-6 Tbsp	4-6 Tbsp
4 lb Barrel	6-8 Tbsp	6-8 Tbsp	8 Tbsp	8 Tbsp

TROUBLESHOOTING

If your tumbler fails to operate correctly, check the following:

Barrel does not turn, turns very slowly, or stops after being placed on tumbler.

No power to unit.	Make sure machine is plugged in correctly. Make sure electrical circuit is operational.
Barrel not installed correctly.	Align barrel correctly.
Barrel too heavy.	Do not exceed rated capacity.
Belt slipping.	Tighten belt.
Drive belt broken.	Remove cover and replace belt.
Motor doesn't run or runs intermittently.	Replace motor.

Barrel leaks or barrel lid comes off during operation.

Inner lid not seated correctly.	Make sure inner lid and barrel shoulder are clean and free of contaminants. Make sure inner lid is seated on shoulder inside barrel.
Knurled nut over tightened.	Tighten knurled nut by hand only until snug. Do not use tools.
Gas build-up in barrel.	Open barrel occasionally to vent gas that might be formed during tumbling.
Barrel or boot gasket damaged.	Replace damaged barrel or boot gasket.

If you need assistance, please contact:

Lortone Customer Service (425) 493-1600

equipment@Lortone.com

MAINTENANCE

LORTONE Tumblers are capable of operating 24 hours/day for years with proper care.

For best operation and results follow these simple, but important steps:

MOTOR: The motor is designed for continuous use and does not need oiling or other maintenance. It is normal for the motor to run hot to the touch.

CLEANING: The outside of the barrel should be kept clean. Clean by wiping with a wet soapy cloth and rinse well with fresh water. **DO NOT** put the barrel in a dishwasher or clean using solvents. If the outside of the barrel becomes so slick that it slips on the rollers, roughen slightly with very fine sandpaper or steel wool.

BEARINGS: Oil each shaft bearing every 30 days of operation, using one drop of lightweight lubricating oil. Do Not Use excessive oil.

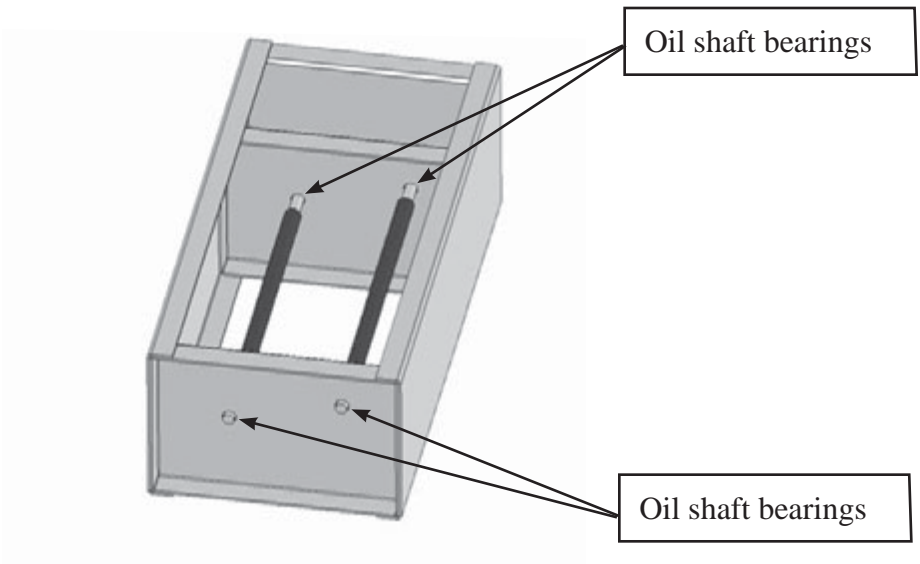

DRIVE BELT: Keep the drive belt tight enough to drive the barrel without being over tightened. Improper tension (too tight) can cause motor bearing failure and belt stretch. To adjust the belt, loosen the three motor mounting nuts, slide the motor to the right, and re-tighten the nuts.

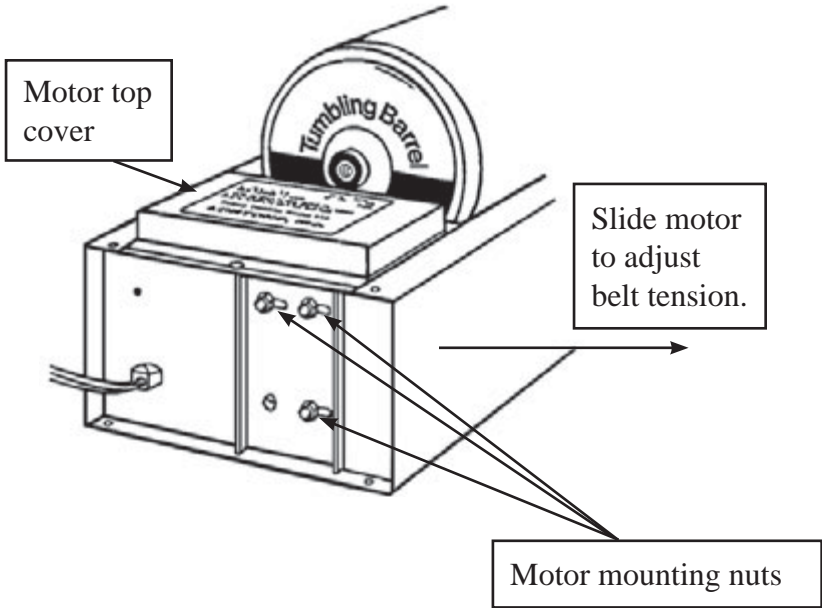

DRIVE BELT REPLACEMENT: Remove the motor top cover and loosen the motor mounting nuts. Remove the old belt and discard. Carefully slip the new belt over the pulleys.

Caution: Pulley edges are sharp! Replace the motor top cover and tighten the belt guard nut.

PARTS LIST 33B, 3-1.5B

Part No.	Description
A 004-104	Frame
B 489-094	Offset Nylon Washer
C 004-005	Motor Cover, Top
D 004-006	Motor Cover, Bottom
E 004-007	Drive Shaft
F 004-008	Idler Shaft
G 001-100	Motor Pulley w/fan
H 004-102	Drive Pulley Assy
I 203-010	Bearings
J 206-012	Retaining Rings
K 210-002	Belt
L 301-034	Motor (110v)
L 301-035	Motor (230v)
M 350-005	Cord
N 320-001	Strain Relief
O 486-021	Screw
P 489-093	Nylon Washer
Q 481-011	Cap Nut
R 209-003	Foot
Part No.	Description
020-091	Complete Rubber Barrel Assembly, 3 lb Capacity (for 33B)
020-090	Complete Rubber Barrel Assembly, 1.5 lb Capacity (for 3-1.5B)
S 020-100	Inner Lid w/Bolt, 3 Lb & 1.5 Lb.
T 020-001	Outer Lid, 3 Lb & 1.5 Lb.
U 481-070	Knurled Nut
V 240-010	Boot Gasket, 3 Lb & 1.5 Lb.
W 240-002	Rubber Barrel Only, 3 Lb.
W 240-001	Rubber Barrel Only, 1.5 Lb.
X 108-001	Barrel Washer

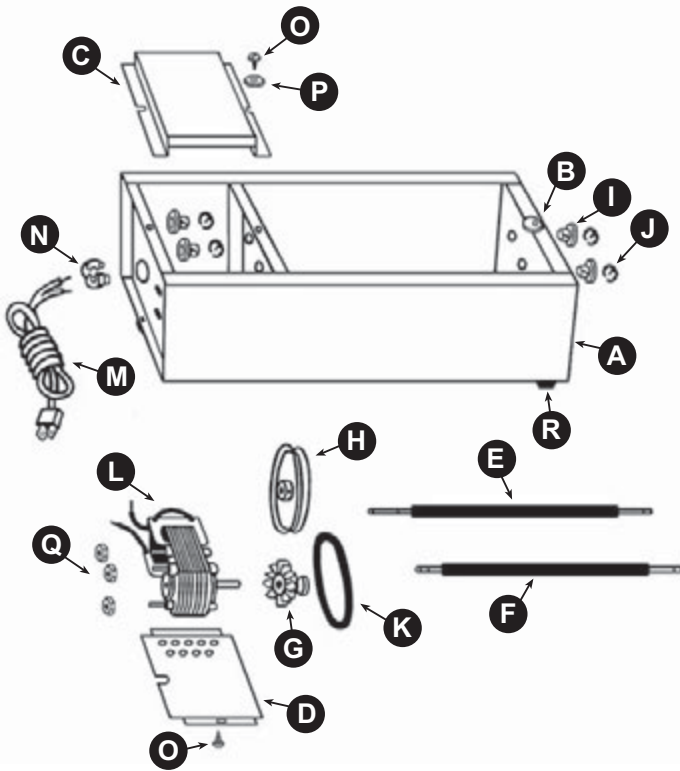

33B & 3-1.5B

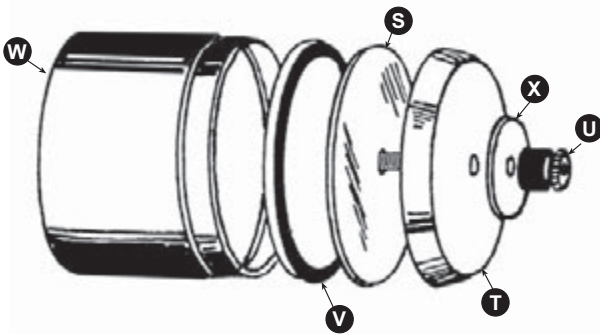

1.5 Lb & 3 Lb. Barrel

PARTS LIST 45C

Part No.	Description
A 004-108	Frame
B 004-010	Barrel Guide w/ hardware
C 004-005	Motor Cover, Top
D 004-006	Motor Cover, Bottom
E 004-001	Drive Shaft
F 004-002	Idler Shaft
G 001-100	Motor Pulley w/fan
H 004-102	Drive Pulley Assy
I 203-010	Bearings
J 206-012	Retaining Rings
K 210-002	Belt
L 301-034	Motor (110v)
L 301-035	Motor (230v)
M 350-005	Cord
N 320-001	Strain Relief
O 486-021	Screw
P 489-093	Nylon Washer
Q 481-011	Cap Nut
R 209-003	Foot
Part No.	Description
020-092	Complete Rubber Barrel Assembly, 4 lb Capacity
S 020-101	Inner Lid w/Bolt, 4 Lb.
T 020-002	Outer Lid, 4 Lb.
U 481-070	Knurled Nut
V 240-011	Boot Gasket, 4 Lb.
W 240-003	Rubber Barrel Only, 4 Lb.
X 108-001	Barrel Washer

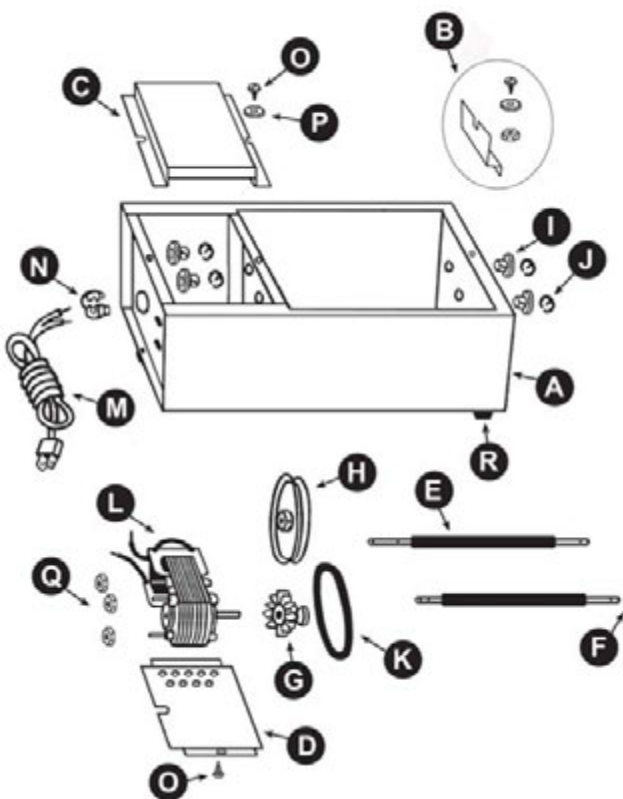

45C

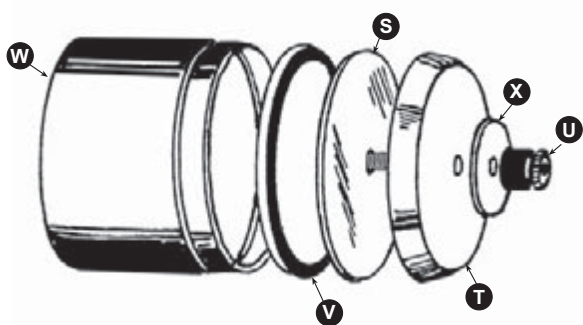

4 Lb. Barrel

**LORTONE Rotary Tumblers
are quiet, durable grinding
and polishing machines.
Follow these basic operating
and care instructions to help
keep your tumbler in optimal
running condition.**

LORTONE

12130 Cyrus Way
Mukilteo, WA 98275
(425) 493-1600